



Dynamic Fire Damper • 3 Hr. Rated • Single Thickness Blade • Horizontal and Vertical Mount • Non-Motorized • Galvanized Steel

STANDARD CONSTRUCTION

- FRAME:** 5½" x 7⁄8" x 16 GA. galvanized steel hat channel.
- BLADES:** 16 GA. galvanized steel, 6" nominal width, parallel action.
- AXLES:** Square, plated solid steel stub.
- BEARINGS:** Oil impregnated bronze.
- LINKAGE:** Plated steel angle and crank plates with stainless steel pivots in-jamb type.
- STOPS:** 18 GA. galvanized steel at head and sill.
- JAMB SEALS:** Stainless Steel.
- FINISH:** Mill.
- ACTUATOR:** Non-motorized spring closure mechanism with 165°F fusible link.

UNDERWRITERS LABORATORIES INC.®
 CLASSIFIED DYNAMIC FIRE DAMPER
 FIRE RESISTANCE RATING 3 HR

FILE # R16591

This fire damper meets the construction and performance requirements of:

- Underwriters Laboratories Inc. Standards 555
- National Fire Protection Association Standards 80, 90A, 101
- ICC's International Building Code

- Underwriters Laboratories Inc. Approved for dual direction airflow and dynamic conditions.
- Underwriters Laboratories Inc. Classified for use in fire resistive ratings of 3 hours or more.

OPTIONS

- 212°F fusible link
- Sleeve of various depths (18" minimum) and gauges
- Round or oval transitions
- Dual position indication package (see note #2)

NOTES

1. Nominal deductions will be made to the opening size given.
2. Optional auxiliary blade position indication switches are rated at 11A, ½HP, 125VAC. These snap action switches are intended to make or break a circuit and will not provide variable or proportional resistance.

DAMPER SIZES

Orientation	Horz & Vert	2000 fpm, 4 in.wg				4000 fpm, 4 in.wg	
		Horizontal (floor)		Vertical (wall)		Horizontal (floor)	Vertical (wall)
Panels	Min Panel	Max Single Panel	Max Assy Panel	Max Single Panel	Max Assy Panel	Max Single Panel	Max Single Panel
Rectangular	4"W x 4"H (8"W x 8"H frame)	30"W x 48"H 36"W x 30"H	60"W x 48"H	36"W x 48"H	126"W x 48"H	30"W x 48"H 36"W x 30"H	36"W x 48"H
Round	6" dia. (8"W x 8"H frame)	28" dia.	46" dia.	34" dia.	46" dia.	28" dia.	34" dia.
Oval	6"W x 6"H (8"W x 8"H frame)	28"W x 46"H 34"W x 28"H	58"W x 46"H	34"W x 46"H	124"W x 46"H	28"W x 46"H 34"W x 28"H	34"W x 46"H

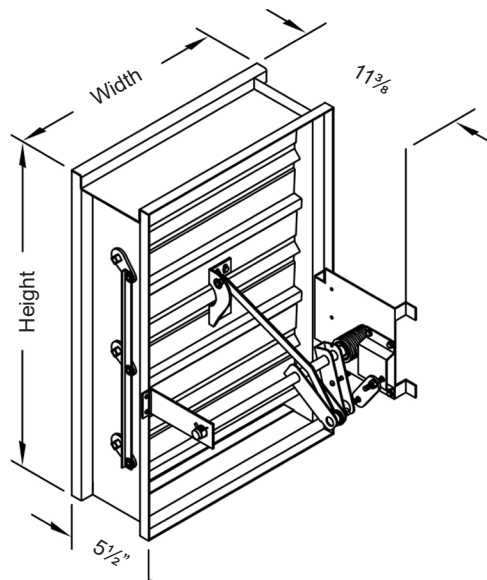

In the interest of product development, Louvers & Dampers reserves the right to make changes without notice.

www.louvers-dampers.com



450 Riverside Drive • Wyalusing PA, 18853 • Phone 570-746-1888 • Fax 570-746-9286

